



VARTA BLUE dynamic EFB

Beneficio clave del vehículo



Preparada para sistemas start-stop básicos



Diseñada según los más altos estándares alemanes



Rejilla PowerFrame® patentada para la máxima potencia de arranque, una recarga rápida y mayor resistencia a la corrosión.



Cumple con todos los criterios originales del fabricante del automóvil

Para más información visite varta-automotive.com

INFORMACIÓN PARA PEDIDOS

Código Europeo (ETN):	595500085
N° artículo:	595500085D842
Referencia Comercial:	N95
Código de barras:	4016987152331
Código UK:	019EFB
Unidad de embalaje:	1
Unidades por palet:	36

INFORMACIÓN TÉCNICA

Tensión [V]:	12	Base Hold-down:	B13
Capacidad de batería [Ah]:	95	Diseño:	0
Corriente de prueba en frío, NE [A]:	850	Tipos de terminales:	1
Longitud [mm]:	353	Tamaño de la carcasa:	H8/LN5
Ancho [mm]:	175	Peso llena y cargada (kg):	24,49
Altura [mm]:	190		

PLANOS

B13

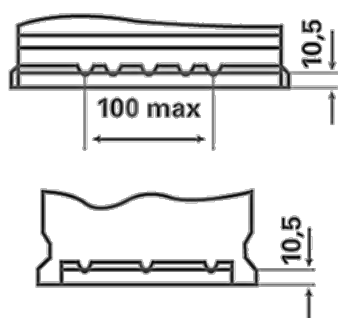

0

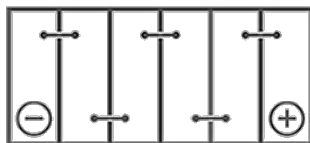

1



3

